



Installation and Operation Manual

**PiezoClamping® - Prestress and charge meter for piezoceramics
(PCG3.1)**



ATCP Physical Engineering

Rua Lêda Vassimon, n° 735-A - Ribeirão Preto - SP / Brazil - Zipcode 14.026-567

Telephone: +55 (16) 3289-9481 / E-mail: ha@atcp.com.br

www.atcp-ndt.com

(This page intentionally left blank)

Installation and Operation Manual

PiezoClamping - Prestress and charge meter for
piezoceramics (PCG3.1)

Manufactured by:

ATCP do Brasil – Alves Teodoro Cerâmicas Piezoelétricas do Brasil Ltda. ME.

Rua Lêda Vassimon, 735-A

Ribeirão Preto - SP, ZIPCODE 14.026-567

Brazilian Industry

www.atcp-ndt.com

Copyright

Copyright © 2018 by ATCP Physical Engineering

All rights reserved.

ATCP reserves the right to change the product and this manual without previous notice.

Version 1.0
July / 2018

This manual was created by the following professionals:

- Mateus Figueiredo (Figueiredo, M. A.);
- Henrique Alves (Pereira, A. H. A.);
- Lucimar Rodolpho (Rodolpho, L. A.);
- Felipe Silva Jorge (Jorge, F. S.).

Table of contents

1. Introduction	7
2. Definitions and symbology	9
3. Applications, testable elements, electric connection and tools	11
4. Operation principles and measurement ranges.....	13
5. Parts, accessories and optional items.....	15
6. Technical specifications, elements' identification and installation	17
7. Configuration, measurement and flow chart	21
8. Troubleshooting, calibration and settings	27
9. Automation interface	35
10. Technical support, warranty terms and statement of responsibility	37
11. References	39

(This page intentionally left blank)

1. Introduction

This installation and operation manual contains important and necessary information for the correct use and maintenance of the PiezoClamping prestress and charge meter for piezoelectric ceramics.



Read this manual carefully before using the equipment. Its misuse can compromise results and cause damage.

PiezoClamping allows measuring the prestress in piezoelectric ceramics of ultrasonic transducers and converters during the assembly and tightening processes. PiezoClamping assists the user in a practical and accurate way by providing the real-time prestress applied to piezoelectric ceramics as they are progressively compressed. PiezoClamping also provides real-time electric charge values generated by piezoelectric ceramics.

Besides the main purpose of instructing the user on how to install, set and operate the PiezoClamping equipment, this manual also aims to contribute to a better understanding of the basic concepts of ultrasonic engineering and of the usual transducer and converter manufacturing procedures.

(This page intentionally left blank)

2. Definitions and symbology

2.1. Definitions

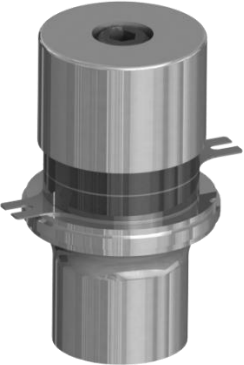
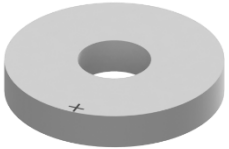
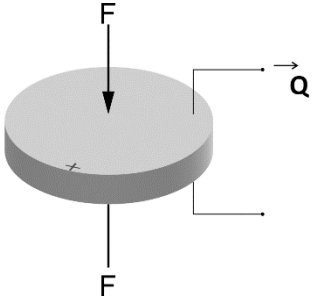
<p>Ultrasonic transducer or converter: Resonant element used to convert alternate electric energy into ultrasonic vibration with a specific frequency. "Transducer" is a general denomination; "converter" is a denomination for the ultrasonic welding area.</p> <p><i>The transducer is composed of piezoelectric ceramic rings compressed between metallic parts connected by a bolt; the electric contact is done through electrodes. This type of transducer, also known as the Langevin-type [1], was originally developed for sonar applications and it had its use later expanded to industrial applications for ultrasonic welding and cleaning [2].</i></p>	 <p>Typical power ultrasonic transducer/converter</p>
<p>Piezoelectric ceramic: It is the active element that converts electric energy into ultrasonic vibration in ultrasonic transducers and converters. They are normally employed in the shape of rings with flat and metalized surfaces.</p> <p><i>The sensitivity of a piezoelectric ceramic piece is specified by the charge constant d_{33}.</i></p>	 <p>Typical piezoelectric ceramic piece.</p>
<p>Piezoelectric charge constant d_{33}: The coefficient between the total electric charge generated and the force applied to the piezoelectric ceramic. The usual charge constant per unit d_{33} is pC/N (picocoulombs per newton). Typical values for the most common PZT ceramics:</p> <ul style="list-style-type: none"> - PZT-8 (Navy type III): 245 ± 35 pC/N - PZT-4 (Navy type I): 290 ± 35 pC/N - PZT-5A: (Navy type II): 390 ± 35 pC/N <p><i>For exact values of the piezoelectric charge constant d_{33}, check with the manufacturer or perform the measurement with a constant d_{33} meter. PZT-8 is commonly used in ultrasonic welding converters and PZT-4, in transducers, for ultrasonic cleaning.</i></p>	 $d_{33} = \frac{Q}{F}$ <p>Charge constant d_{33}.</p>

Piezoelectric Ceramics prestress: Prestress is the tightening applied to the piezoelectric ceramics of power ultrasonic transducers during assembly. Its function is to simultaneously maximize the operating power and the mechanical coupling of the ceramics, besides ensuring that these do not move when vibrating.

The optimum prestress essentially depends on the maximum mechanical stress supported by the piezoelectric material [3,4] and not on its dimensional aspects, as it occurs with the optimum tightening torque that varies with the area of the ceramics, and with the friction coefficient of the bolt with the metallic masses. The typical values as a function of the piezoelectric material are 45 MPa, for PZT-8 ceramics used in welding converters and medical equipment; and 35 MPa, for PZT-4 ceramics used in ultrasonic cleaning transducers.

Prestress is a key factor for the lifespan, maximum power and efficiency of the transducer. Nonetheless, the excess of prestress changes the properties of the ceramics and can cause crushing. On the other hand, the lack of it causes the lateral displacement of the ceramics, leading to the occurrence of cracks, electric arcs and short circuits.

2.2. Symbology

	Attention! Danger!	VAC Volts alternating current	VA Volt-Ampere
VDC	Volts direct current	I Switches the equipment on	O Switches the equipment off

3. Applications, testable elements, electric connection and tools

3.1. Applications

PiezoClamping is a robust and easy-to-use solution to manufacture, recover and develop power ultrasonic transducers and converters. Its functions and characteristics have been designed to offer an accurate and standardized procedure for the assembling process and prestress application in the following sectors:

- Manufacturers of power ultrasonic machines and equipment.
- Repair service providers of ultrasonic welding machines and power ultrasonic equipment in general.
- Research groups, educational institutions and R&D departments.

3.2. Testable elements

PiezoClamping can be used to measure the prestress of Langevin-type [1] piezoelectric transducers and converters and of similar devices in which prestress is applied to piezoelectric ceramics, such as the followings:

- Converters for ultrasonic cutting and welding machines.
- Transducers for die polishing machines.
- Transducers for ultrasonic cleaning machines and equipment.
- Tubular transducers for sonoreactors, sonochemistry and biodiesel processing.
- Ultrasonic transducers for dental, medical and esthetic equipment.

3.3. Electric connection

PiezoClamping must be connected to the transducer using the test probe that comes with the equipment and has the configuration parameters set for the specific characteristics of ceramics of the transducer being assembled.

The alligator clips must be connected to the transducer electrodes or to the wires attached to them, as shown in the photo. The red clip must be connected to the positive electrode (live) and the black one to the electrode in electric contact with the metallic masses (ground).



Connect the terminals of the transducer or converter to PiezoClamping before tightening. A high voltage discharge may damage the equipment.



Electrical connection between PiezoClamping and the transducer.

3.4. Tools

The tightening of transducers and converters can be done by using a key or a torque wrench set for a torque equal to 120% of the average torque value to achieve the desired prestress. Using a torque wrench is optional and it aims to protect the bolt from excessive tightening in the case of it stuck. It is also recommended using a vise or similar equipment that allows fixing the transducer to avoid rotation during tightening without damaging it.



PiezoClamping connected to control the prestress of a converter.



Do not connect PiezoClamping to ultrasonic power generators or to energized circuits because it will get damaged. PiezoClamping must be connected to passive elements only.

4. Operation principles and measurement ranges

4.1. Operation principles

The operation principles of PiezoClamping consists in integrating the electric charge generated by the piezoelectric ceramics during the transducer or converter tightening and then, based on the charge constant d_{33} and other characteristics of the ceramics, the prestress is calculated in MPa. When compressed, piezoelectric ceramics generate an electric charge proportional to the compression, and this proportionality is given by the charge constant d_{33} . PiezoClamping employs an advanced measurement process that provides a reproducible result, stable over time and independent of the tightening speed. The user can change the tightening speed and pause the process with no significant loss of data. PiezoClamping also reports the total electric charge in μC .

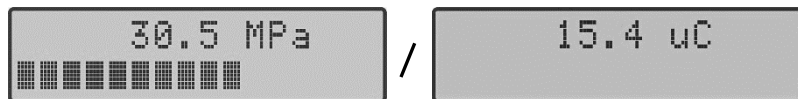

Example of the measurement and results screens presented by PiezoClamping: prestress in MPa, with the proportional bar graph on the left; and total electric charge measured in μC on the right.

Note: One of the traditional approaches for prestress control consists in monitoring the tightening torque of the bolt. Nevertheless, this method presents low accuracy because the ratio between torque and prestress varies drastically as a function of finishing surface, lubrication and possible sticking [5]. Another traditional approach involves using a capacitor with a voltmeter to measure the electric charge generated during the tightening. This arrangement is better than the control by torque only, but it also presents low accuracy because the charge generated by the ceramic and stored by the capacitor is consumed by the meter, making the measurement unstable. Additionally, the obtained value is an electric voltage proportional to the force and it is necessary to perform calculations to determine the prestress [4].

4.2. Measurement ranges

The PiezoClamping prestress measurement range goes from 0.1 to 99.9 MPa and the charge range from 0.1 to 999.9 μC . PiezoClamping is suitable for testing transducers and converters that use from 1 to 8 piezoelectric ceramics in their assembly, with the d_{33} charge constant between 1 and 999 pC/N. To facilitate its use, PiezoClamping displays the prestress value in MPa and also in the percentage referenced by the target prestress set by the user. The percentage information is provided by means of the target bar graph with ten rectangles (from 0 to 100%, with steps of 10%).

In addition to the target bar graph, the display also has a two-dimensional Speed/Vin bar graph in its bottom right corner, where the horizontal variation is linearly proportional to the tightening speed (*Speed*) and vertically proportional to the input voltage. The Speed/Vin bar graph only appears during the tightening process (whilst there is electric charge movement).

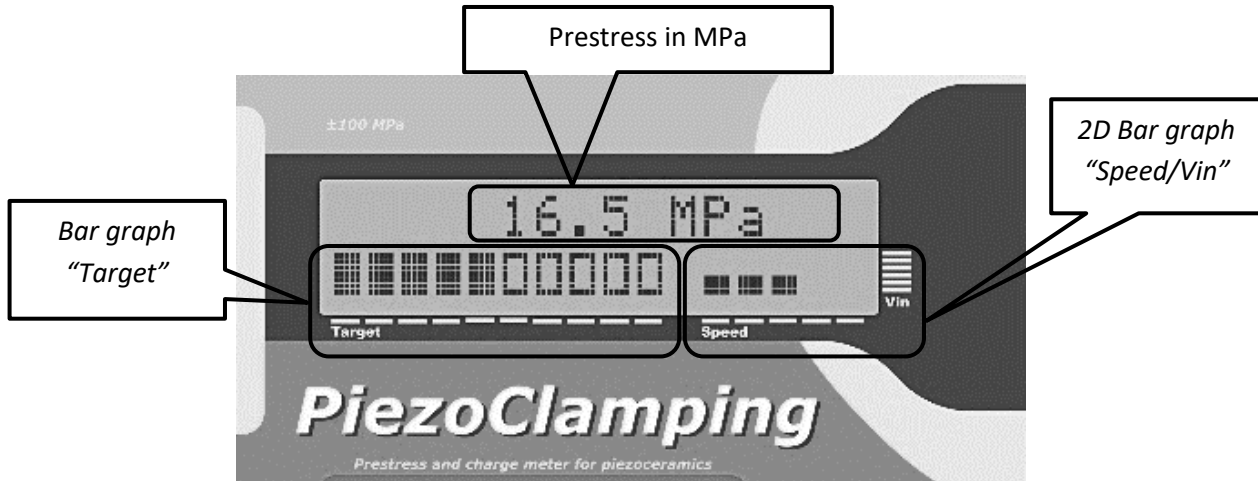

Example of a screen displayed during the measuring process.



The Speed/Vin bar graph should not reach its limits whilst the prestress is being applied. If that occurs for the Speed, the user will be alerted by a beeping noise; if it occurs for the Vin, the message "overload" will be displayed and the measurement will be aborted.

PiezoClamping comes with a self-protection system that activates a safety relay for the discharge of piezoelectric ceramics whenever the input voltage is exceeded (when the vertical dimension of the Speed/Vin bar graph reaches its full scale). In that case, PiezoClamping restarts the measurement automatically by disregarding the prestress and electric charge data. In addition, the OVERLOAD screen (pictured below) is displayed and a warning sound follows.

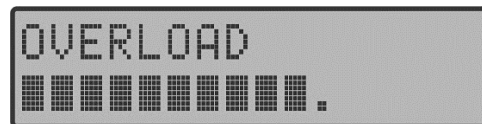

Screen accusing overload.

5. Parts, accessories and optional items

PiezoClamping is provided with the items described next.



Parts:

01 - PiezoClamping - Prestress and charge meter for piezoelectric ceramics.

Accessories:

02 - 1.8-meter tri-polar power supply cable (standard ABNT NBR 14136:2012).

03 - 1.0-meter probe with alligator clips.

04 - Connector for the PLC Interface.

05 - Instruction Manual.

(This page intentionally left blank)

6. Technical specifications, elements' identification and installation

6.1. Technical specifications

Measuring and precision range

Prestress	0.1 - 99.9 MPa
Electrical charge	0.1 - 999.9 uC
Precision	± 1 %
Accuracy	± 3 %

Setting parameters

Trigger voltage	0.4 - 10.0 mV
Outer diameter	1.0 - 99.9 mm
Inner diameter	0.0 - 98.9 mm
Number of piezoceramics	1 - 8
Charge constant (d_{33})	10 - 999 pC/N
Target prestress.....	1.0 - 99.9 MPa
Prestress time	0.1 - 10.0 seconds
Dimensions input mode	T. sizes and Custom
Calibration (<i>Z setting</i>)	0.950 - 1.050

Other specifications

Electrical shock protection	Class I
Protection level IP	IP40
Operation mode	Continuous
AC input	90 - 260 VAC
Frequency	50 - 60 Hz
Maximum power consumption (stand by)	16 Watts rms
Maximum power consumption (in operation)	50 Watts rms
Equipment dimensions (L x P x A)	260 x 250 x 100 mm
Packaging dimensions.....	370 x 330 x 140 mm
Equipment weight without packaging.....	3.8 kg
Equipment weight with packaging	4.4 kg
Working temperature range.....	From -10 to +45 °C

6.2. Elements identification

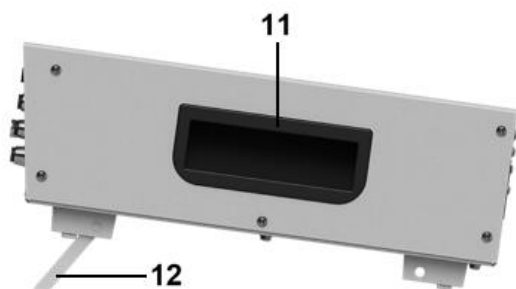
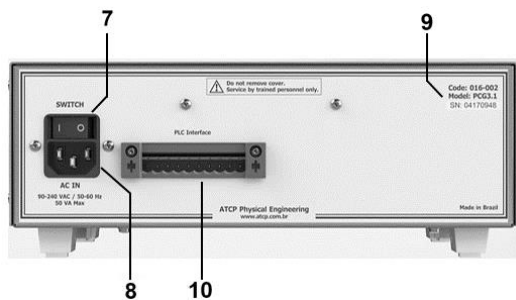
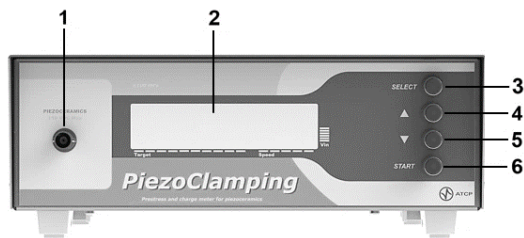

[1] PIEZOCERAMIC Connector: BNC-type connector for connecting the test element. The maximum input voltage is ± 10 VDC

[2] Display: Alphanumeric interface of 2 lines by 16 characters.

[3] SELECT pushbutton: Pushbutton-type of button to choose between the MEASURING screen and the other CONFIGURATION screens available.

[4] and [5] pushbuttons "▲" (up) e "▼" (down): Pushbutton-type of buttons to increase and decrease values. The "MPa" or " μ C" options can be selected from the MEASUREMENT screen. In the CONFIGURATION screens, you can increase, decrease and select values.

[6] START pushbutton: Pushbutton-type of button to start a new measurement. Each time it is pressed, the system automatically performs the "tare" of the equipment for a new measurement procedure.

[7] "SWITCH" key: Key to switch the equipment on and off.

[8] AC IN: Input connector for the power supply cable (90-240 automatic VAC – 50/60Hz)

[9] TAG: Code, model and serial number of the equipment.

[10] PLC Interface: Connector for external communication using PCL.

[11] Side handle: handle for handling and transportation.

[12] Tilt legs: Removable legs located on the front feet for the frontal elevation of the equipment.

6.3. Installation

Minimum requirements:

- Firm, flat and spacious enough bench for the PiezoClamping equipment and transducers to be mounted.
- Electric power outlet of 90-260 VAC 50-60 Hz, with grounding. If the mains are not grounded, use an isolating transformer for safety.
- Vise or similar equipment fixed to the bench to hold the transducer front mass during tightening.

Step-by-step procedure:

Step 01 Place the equipment on the workbench and set the tilt legs [12] to the most appropriate position for visualizing the display.



Step 02 Connect the power supply cable to the AC IN connector [8] on the rear panel and into a properly grounded outlet or a stabilizing isolator.

Step 03 Connect the BNC connector at the end of the probe supplied with the equipment to the PIEZOCERAMIC connector [1] located on the left side of the front panel.



(This page intentionally left blank)

7. Configuration, measurement and flow chart

7.1. Equipment configuration for the transducer set to be measured

Step 01 Switch the equipment on using the SWITCH [7] key located on the rear panel. The opening message will be presented first, and then it will be followed by the initial measuring screen in MPa.

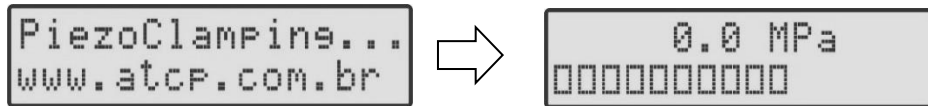

Step 02 Press SELECT [3] to access the Piezo diam. (mm) configuration screen. It presents the options for outer diameters (OD) and inner diameters (ID), previously set to facilitate the equipment use.

```
Piezo diam. (mm)
OD 38.1 ID 19.1
```

Step 03 Use [▲] or [▼] to choose between the available options, as shown in the table below:

Piezo diam. (mm) OD 10.0 ID 4.0	Piezo diam. (mm) OD 10.0 ID 5.0	Piezo diam. (mm) OD 11.0 ID 5.5	Piezo diam. (mm) OD 15.0 ID 6.0
Piezo diam. (mm) OD 20.0 ID 9.8	Piezo diam. (mm) OD 20.0 ID 10.0	Piezo diam. (mm) OD 25.0 ID 10.0	Piezo diam. (mm) OD 25.0 ID 12.0
Piezo diam. (mm) OD 30.0 ID 10.0	Piezo diam. (mm) OD 32.0 ID 10.0	Piezo diam. (mm) OD 32.0 ID 12.0	Piezo diam. (mm) OD 35.0 ID 15.0
Piezo diam. (mm) OD 38.0 ID 15.0	Piezo diam. (mm) OD 38.1 ID 12.7	Piezo diam. (mm) OD 38.1 ID 19.1	Piezo diam. (mm) OD 40.0 ID 12.0
Piezo diam. (mm) OD 40.0 ID 15.0	Piezo diam. (mm) OD 40.0 ID 17.0	Piezo diam. (mm) OD 40.0 ID 20.0	Piezo diam. (mm) OD 45.0 ID 15.0
Piezo diam. (mm) OD 45.0 ID 20.0	Piezo diam. (mm) OD 46.0 ID 15.8	Piezo diam. (mm) OD 50.0 ID 16.0	Piezo diam. (mm) OD 50.0 ID 17.0
Piezo diam. (mm) OD 50.0 ID 20.0	Piezo diam. (mm) OD 50.8 ID 19.1	Piezo diam. (mm) OD 50.8 ID 25.4	Piezo diam. (mm) OD 55.0 ID 20.0
Piezo diam. (mm) OD 55.0 ID 25.0	Piezo diam. (mm) OD 60.0 ID 20.0	Piezo diam. (mm) OD 60.0 ID 30.0	Piezo diam. (mm) OD 69.0 ID 33.0
Piezo diam. (mm) OD 70.0 ID 30.0	Piezo diam. (mm) OD 70.0 ID 33.0		

Attention: The options for "Piezo diam. (mm)" are only accessible if the configuration parameter "Dim. input mode" is set to "Typical sizes" (factory default). The parameter configuration "Dim. input mode" for the "Custom" option will be later described in detail.

Step 04 Press SELECT [3] to access the "Number of Piezo" configuration screen and enter the quantity of piezoelectric ceramics of the transducer to be assembled (from 1 to 8 ceramics).



```
Number of Piezos
4
```

Step 05 Use [▲] or [▼] to change the quantity.

Step 06 Press SELECT [3] to access the "d₃₃" configuration screen and enter the d₃₃ value of the piezoelectric ceramics. Typical values are 245 pC/N for PZT-8, 290 pC/N for PZT-4, and 390 pC/N for PZT-5A.

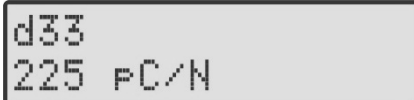

```
d33
225 pC/N
```

Step 07 Use [▲] or [▼] to change the d₃₃ value.

Step 08 Press SELECT [3] to access the "Compress. Target" configuration screen. Enter the desired prestress value in MPa (from 1.0 to 99.9 MPa). The typical values are 45 MPa for PZT-8 and 35 MPa, for PZT-4.



```
Compress. target
30.0 MPa
```

Step 09 Use the [▲] or [▼] pushbuttons to change the quantity.

Step 10 Press SELECT [3] to access the "Compression time" configuration screen. Enter the minimum time required to tighten the transducer (from 0.1 to 10.0 seconds).



```
Compression time
0.4 s
```

Step 11 Use [▲] or [▼] to change the minimum tightening time.

Step 12 Press SELECT [3] to the last configuration screen, "Dim. input mode". Select the input mode of the ceramic dimensions. There are two options: "Typical sizes", for pre-configured dimensions, and "Custom", for manual insertion.



```
Dim. input mode
Typical sizes
```

Step 13 Use [▲] or [▼] to switch between the two available options.

Step 14 After all parameters have been set, press SELECT [3] to finish the configuration and return to the initial measurement screen.

Attention: If the user chooses the "Custom" configuration option in the "Dim. Input mode", the equipment will present the "Outer diameter" screen at the beginning of the configuration (previously described in Steps 02 and 03). After that, by pressing SELECT [3], the "Inner Diameter" ceramics configuration screen will be displayed. In that case, use the following steps to configure the ceramic dimensions to be used instead of following the steps 02 and 03 previously described.

Step 02a Press SELECT [3] to access the first configuration screen called "Outer diameter". Insert a value between 1.0 to 99.9 mm for the outer diameter of the ceramic.

Step 03a Use [▲] or [▼] to change between the outer diameter (OD) value options available.

Step 02b Press SELECT [3] again to access the next configuration screen, called "Inner Diameter". Insert a value between 0.0 and 98.9 mm for the inner diameter (ID) of the ceramic.

Step 03b Use [▲] or [▼] to change between the inner diameter (ID) value options available.

Note: If the outer diameter (OD) is configured to values smaller than the inner diameter + 1.0 mm, the inner diameter will be set automatically by displaying the "Id adjst" warning and vice-versa, as shown next:

<pre>Inner diameter 30.0 mm Od adjst</pre>	or	<pre>Outer diameter 30.0 mm Id adjst</pre>
--	----	--



The values of d_{33} and prestress ("Compress. Target") should be obtained from the manufacturer of the piezoelectric ceramics. In the absence of this data, consider d_{33} equal to 245 pC/N for PZT-8, and 290 pC/N for PZT-4; and prestress 45 MPa for PZT-8 and 35 MPa, for PZT-4.

7.2.Measurement

Step 01 Use the SWITCH [7] key located on the rear panel to turn the equipment on. The initial PiezoClamping opening message will be displayed for a few seconds, followed by the initial MPa measurement screen.

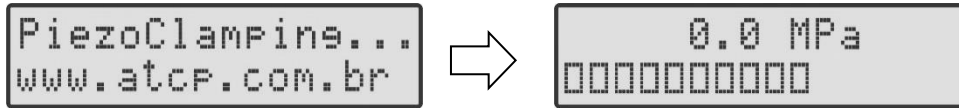

Step 02 Note the correct position of the polarities, connect the probe alligator clips to the transducer terminals, which should be with its metallic front part fixed to enable the tightening and the desired prestress.

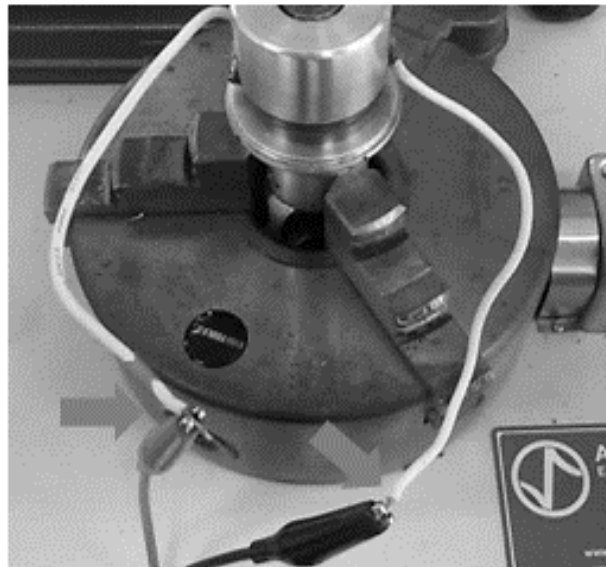

Step 03 Configure the parameters of the ceramics in the PiezoClamping equipment. Section 7.1 describes the configuration process in detail.

Step 03 Press START [6] to begin the measurement. At this moment the equipment will tare the values, presenting the STARTING screen, the quantity and the dimensions of the ceramics configured for a few seconds to inform the user.

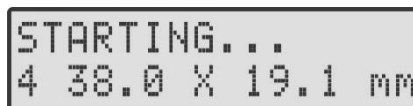

After that, the equipment will present the initial measuring screen automatically and wait for the user to start the tightening process of the transducer set.



Step 04 Couple the key or torque wrench to the bolt of the transducer and tighten it progressively and carefully observing the information presented on the PiezoClamping display screen.



As tightening is performed, the prestress value is presented in MPa in real-time on the superior line of the display screen. On the bottom line, the bar graph shall be filled progressively as the desired prestress is being reached (Compress. Target).

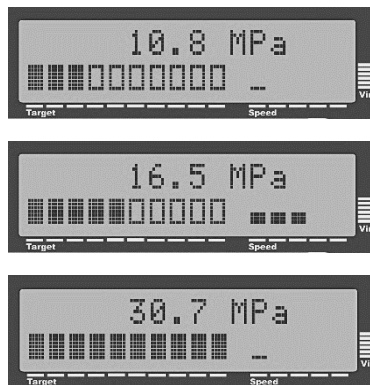

At the same time, the display screen will present a second bar graph (to the left of the percentage bar graph) proportional to the prestress application speed (horizontal bar), and to the input voltage generated by the piezoelectric ceramics (vertical bar). If the maximum speed or input voltage exceeds the equipment's acceptable limits (± 10 VDC), the bi-dimensional bar graph will be fully filled and a beeping sound will warn the user of it.

7.3. General flow chart

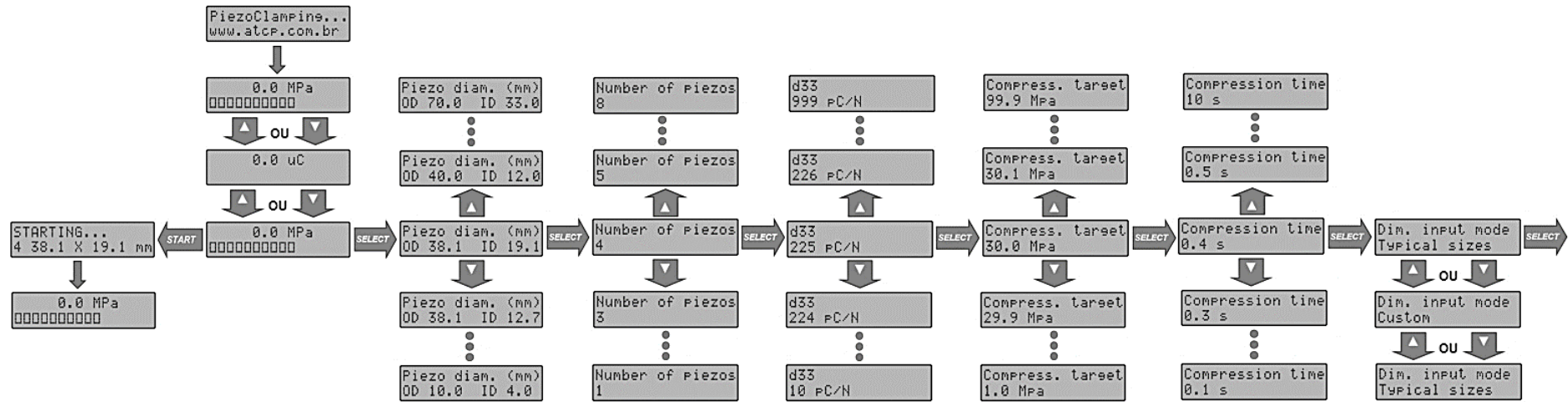

Sequence of screens of the equipment under the "Dim. Input mode" option, configured for "Typical sizes".

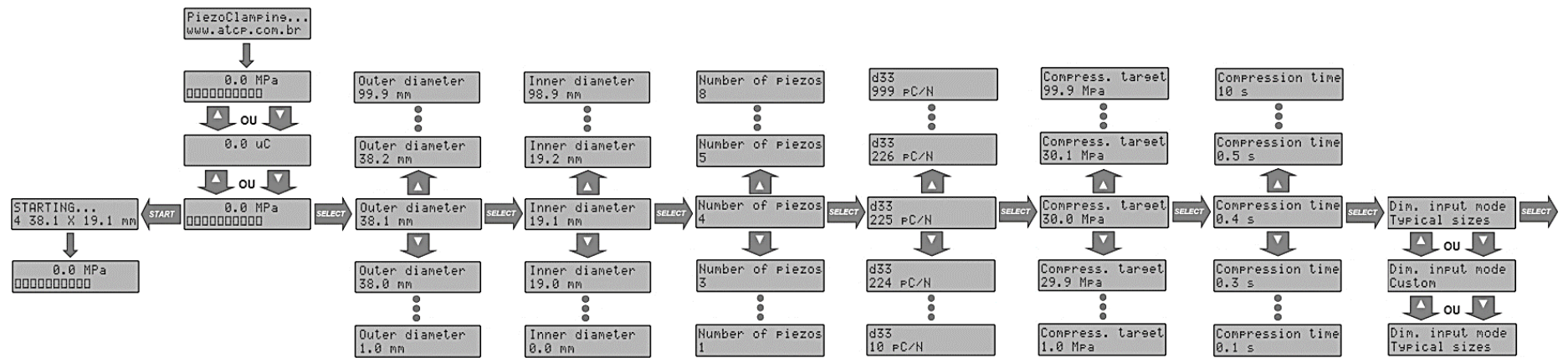

Sequence of screens of the equipment under the "Dim. Input mode" option, configured for "Custom"

8. Troubleshooting, calibration and settings

8.1. Troubleshooting

Problem	Possible cause	Solution
PiezoClamping does not turn on.	The power outlet lacks electrical power.	Use a power outlet with electrical power available.
	The power supply cable is not connected to the power outlet and/or to the PiezoClamping equipment.	Connect the power supply cable.
	The power supply cable is damaged.	Replace the damaged cable for another one in good conditions.
	The I/O key (Switch) is on the "off" position.	Move the key to the "on" position.
PiezoClamping cannot do the metering, or The measurement is in steady, or The measurements are not reproducible.	The probe is not connected to the equipment.	Connect the probe to the PIEZOCERAMIC connector.
	The probe presents poor contact or one of the wires has been interrupted.	Fix or change the probe.
	The probe has been connected incorrectly to the element being tested.	Check if the probe is connected to the correct pins or terminals (red end to live and black end to ground).
	The configuration parameters are incorrect.	Configure it correctly, according to the specifications of the assembled transducer.
	PiezoClamping lacks calibration.	Perform the calibration of the equipment (see section 8.2) and check its settings (8.3 and 8.4). If that is not possible, contact ATCP Physical Engineering.
PiezoClamping captures a signal without the tightening of the ceramic piece, or even with no connection with the probe.	PiezoClamping is capturing environmental electromagnetic interferences.	Increase the triggering level (section 8.4). If the problem remains, contact ATCP Physical Engineering.

8.2. Calibration

This section describes the calibration procedure for PiezoClamping. Necessary items:

- Capacitor with nominal capacitance of 2.2 μF and known uncertainty.
- Adjustable voltage source with nominal value between 2.5 and 10 VDC and known uncertainty.

Step-by-step procedure:

Step 01 Turn the equipment on. Then press [\blacktriangledown] to access the charge display screen, as shown in the figure below:

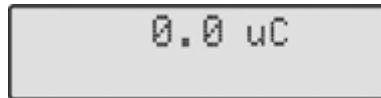

Step 02 Connect the BNC connector of the probe supplied with the equipment to PiezoClamping.



Step 03 Press [START] to tare the equipment and start a new charge measurement.

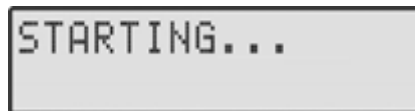

Step 04 Connect the voltage source to the capacitor, as shown in the figure below, so it is charged.

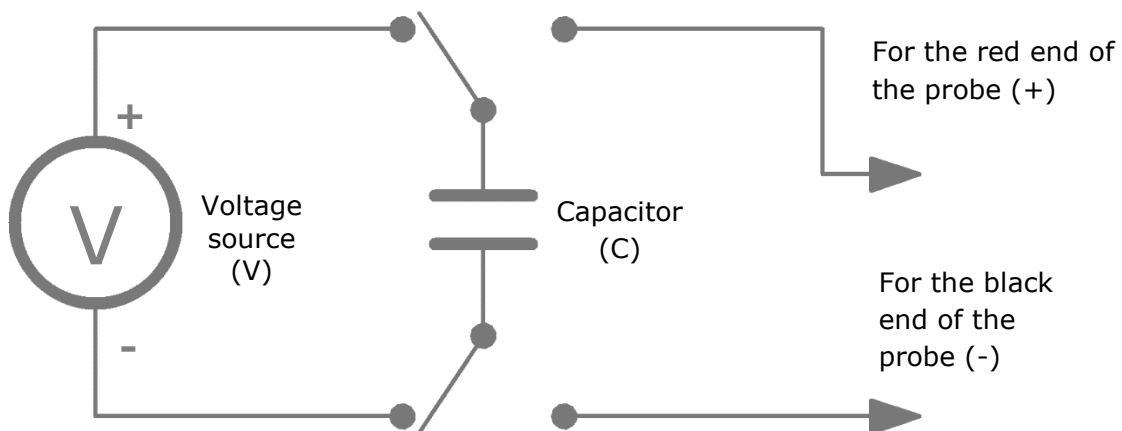

Step 05 Disconnect the capacitor from the voltage source and connect it to the PiezoClamping input as shown next, so that the capacitor charge is measured by PiezoClamping. Write the obtained value down.

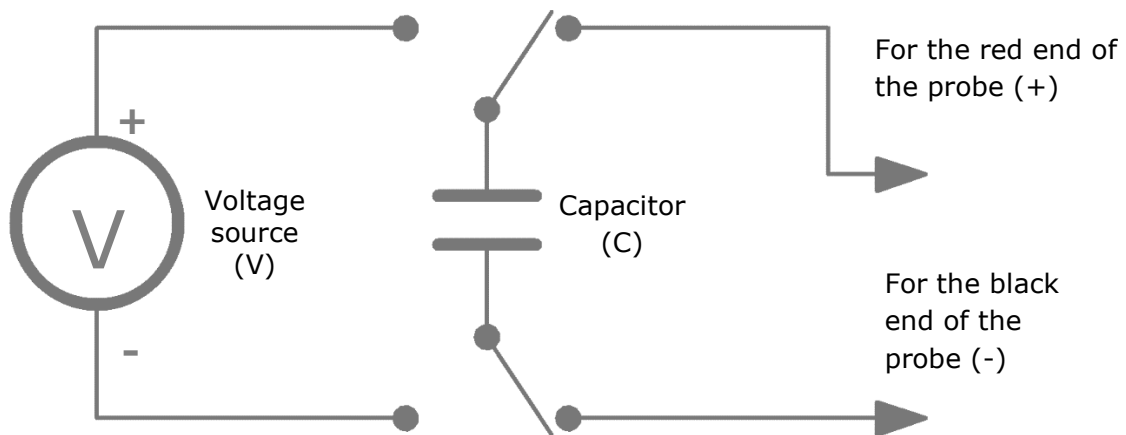

Step 06 Use the equation (1) below to calculate the expected charge value (Q_E) to be measured by PiezoClamping as a function of the capacitance (C) and voltage (V) employed.

$$Q_E = C \times V \quad (1)$$

Attention: The expected value (Q_E) is calculated based on the capacitance and voltage values considered by the user. In order to compare the expected value with the measured value, it is necessary to take the respective measurement uncertainty (I_{QE}) into account, as detailed in the following step.

Step 07 Use the equation (2) to calculate the combined uncertainty (I_{QE}) of the electric charge generated in PiezoClamping with its uncertainty. The uncertainty of PiezoClamping can be considered as the sum of its precision (1%) with its accuracy (3%).

$$I_{QE} = 2 * Q_E * \sqrt{\frac{I_V^2}{V} + \frac{I_C^2}{C} + \frac{I_{PZC}^2}{Q_E}} \quad (2)$$

where I_V is the voltage source uncertainty, I_C is the capacitor uncertainty and I_{pzc} is the PiezoClamping's measurement uncertainty.

Step 08 The electric charge measured (Q_m) must be within the range:

$$(Q_E - I_{QE}) \leq Q_m \leq (Q_E + I_{QE}) \quad (3)$$

If the value measured by PiezoClamping falls within the range above, the meter is calibrated and nothing needs to be done. If the value measured by PiezoClamping is outside the range, the electric charge measurement setting is required (see topic "8.3. Electric charge measurement setting").

Attention: The accuracy of the calibration depends on the accuracy of the capacitor and voltage source used.

Calibration example:

Used devices:

- Voltage reference AD584-M with 4 selectable output voltage options: 2,500 V; 5,000 V; 7,000 V and 10,000 V with accuracy of 0.1%.

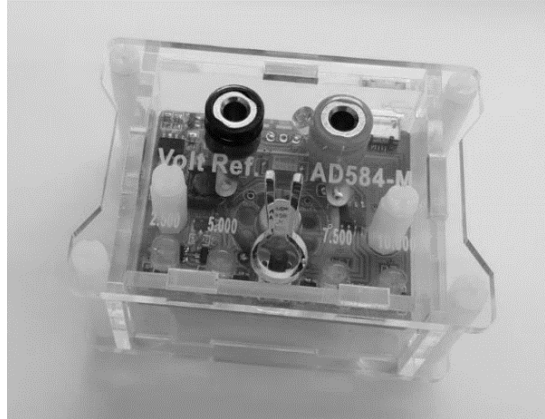

- 2.2 uF bipolar capacitor with 2% accuracy (equivalent commercial model: KEMET F461DO225G250L, Mouser code 80-F461DO225G250L), encapsulated to facilitate its use.



It is advisable to calibrate both the capacitor and the voltage source.

The AD584-M reference voltage options (2.5000, 5.0000, 7.5000 and 10.0000 VDC) and the 2.2 uF capacitor will provide charges ranging from 5.5 to 22.0 uC, which match the typical charge range for transducers of two piezoelectric ceramics. For instance, a transducer with two PZT-8 ceramics and 45 MPa of prestress will generate approximately 18.75 uC when tightened. To perform calibration outside the charge ranges, higher capacitors or additional capacitors can be used in parallel. Nevertheless, be aware: users should not employ voltage references above 10 VDC or below 2 VDC.

Calculation of the acceptance ranges:

Parameters and range for the 2.5000 VDC voltage:

	V / I _V	2,5000 VDC / 0.0025 (0.1%)
	C / I _c	2,200 uF / 0.044 uF (2%)
	I _{PZC}	0.22 uC (4%*)
Calculation eq. (1)	Q _E	5.50 uC
Calculation eq. (2)	I _{QE}	0.49 uC (8.91 %)
	Q _E + I _{QE}	5.99 uC
	Q _E - I _{QE}	5.01 uC
Acceptance range:	5.01 ≤ Q_m ≤ 5.99 μC	

Parameters and range for the 5.0000 VDC voltage:

	V / I _V	5.0000 VDC / 0.0050 (0,1%)
	C / I _c	2.200 uF / 0.044 uF (2%)
	I _{PZC}	0.44 uC (4%*)
Calculation eq. (1)	Q _E	11.00 uC
Calculation eq. (2)	I _{QE}	0.98 uC (8.91 %)
	Q _E + I _{QE}	11.98 uC
	Q _E - I _{QE}	10.02 uC
Acceptance range:	10.02 ≤ Q_m ≤ 11.98 μC	

Parameters and range for the 7.5000 VDC voltage:

	V / I _V	7.5000 VDC / 0.0075 (0.1%)
	C / I _c	2.200 uF / 0.044 uF (2%)
	I _{PZC}	0.66 uC (4%*)
Calculation eq. (1)	Q _E	16.50 uC
Calculation eq. (2)	I _{QE}	1.47 uC (8.91 %)
	Q _E + I _{QE}	17.97 uC
	Q _E - I _{QE}	15.03 uC
Acceptance range:	15.03 ≤ Q_m ≤ 17.97 μC	

Parameters and range for the 10,0000 VDC voltage:

	V / I _V	10.0000 VDC / 0.0100 (0.1%)
	C / I _c	2.200 uF / 0.044 uF (2%)
	I _{PZC}	0.66 uC (4%*)
Calculation eq. (1)	Q _E	22.00 uC
Calculation eq. (2)	I _{QE}	1.96 uC (8.91 %)
	Q _E + I _{QE}	17.97 uC
	Q _E - I _{QE}	15.03 uC
Acceptance range:	20.04 ≤ Q_m ≤ 23.96 μC	

Measured charge values vs. acceptance ranges:

Voltage	Acceptance range	Measured charge (Q_m)	Judgement
2.5000 VDC	$5.01 \leq Q_m \leq 5.99 \mu\text{C}$	5.58 μC	Ok
5.0000 VDC	$10.02 \leq Q_m \leq 11.98 \mu\text{C}$	11.14 μC	OK
7.5000 VDC	$15.03 \leq Q_m \leq 17.97 \mu\text{C}$	16.66 μC	Ok
10.0000 VDC	$20.04 \leq Q_m \leq 23.96 \mu\text{C}$	22.24 μC	Ok

As the values measured by PiezoClamping are within the acceptance ranges, the equipment is calibrated and nothing needs to be done. If any of the results were out, you would need to set the charge measurement as described in the next topic.

8.3. Electric charge measurement setting

It is possible to adjust the PiezoClamping for charge measurement and, as a result, for prestress too. This setting is necessary when PiezoClamping fails the calibration.

Step-by-step procedure:

Step 01 Access the setup menu by turning PiezoClamping on with the [SWITCH] key while simultaneously holding down [SELECT] and [▲]. Release both pushbuttons only when the equipment displays the "Z adjust" correction factor, as shown below (the value shown may be different):



Z adjust: 1.009

Step 02 Set the "Z adjust" correction factor using the [▼] and [▲] pushbuttons. The "Z adjust" is a multiplicative factor of the charge measurement and must be change to the inverse proportion of the deviation observed in the measurement of the electric charge. If the observed deviation happens so it considers smaller values, it is necessary to increase the value of the parameter "Z adjust" and vice-versa. The setting process must be interactive and intercalated with the repetition of the electric charge calibration. If a satisfactory setting cannot be made between 0.950 and 1.050, PiezoClamping must be sent for service.

Step 03 To exit the setting mode, turn PiezoClamping off and on using the [SWITCH] key. The new "Z adjust" value will be saved automatically.

8.4. Trigger level setting

It is possible to set the trigger voltage level for the signal acquisition via PiezoClamping by changing the "Trigger level" parameter. This setting may be necessary for places with electromagnetic interferences that are capable of triggering the acquisition without a transducer connected or being tightened.

Step-by-step procedure:

Step 01 Access the setting menu by pressing the [SWITCH] key while pressing the [▼] and [▲] pushbuttons simultaneously. Release them only when the device displays the "Trigger level" parameter, as shown below (factory default is 4.8 mV):

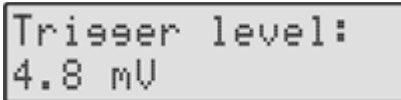

```
Trigger level:  
4.8 mV
```

Step 02 Set the "Trigger level" parameter using the [▼] and [▲] pushbuttons. The "Trigger level" is the reference parameter used by PiezoClamping to determine if the voltage at the input connector is a real signal and should be accounted for, or if it is just a noise.

Attention: "Trigger level" must be kept as close to 4.8 mV as possible. Above values will cause loss of information and deterioration of the accuracy of the equipment.

Step 03 To exit the setting mode, turn PiezoClamping off and on using the [SWITCH] key. The new "Trigger level" value will be saved automatically.

(This page intentionally left blank)

9. Automation interface

PiezoClamping is fitted with an automation interface that allows its integration with PLC, as shown in the picture below:

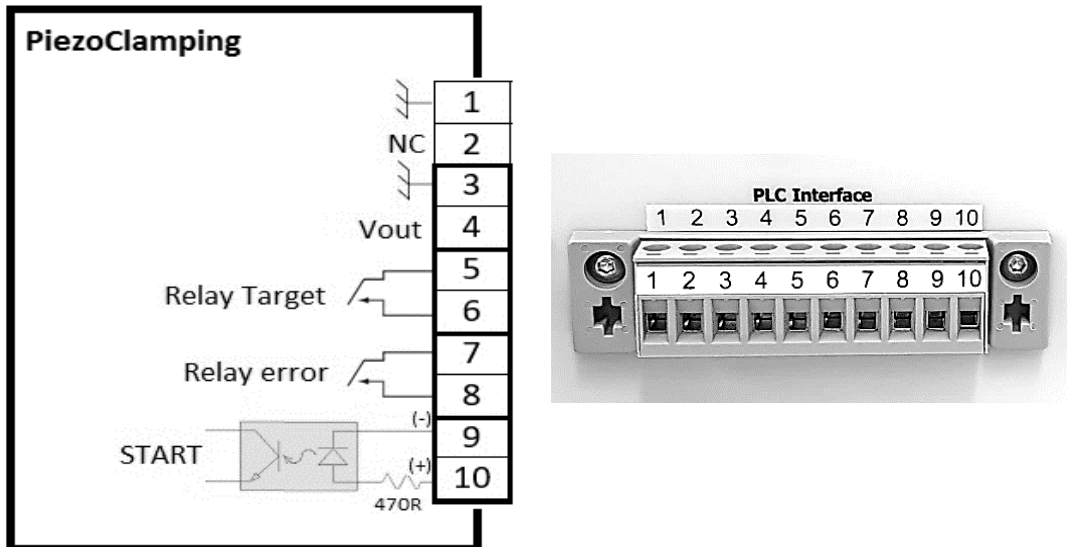

Parameters and ranges of each position of the connector:

Ground (positions 1 and 3): Ground pins for the Vout voltage reference. These pins are also connected to the ground pin of the power supply cable.

Vout (position 4): Analog voltage output VDC proportional to the target prestress ("Compress. Target"), with values between 0 VDC for 0% and 10 VDC for 200% of the target prestress. Note: This output is not isolated. The equation below describes the dependence between Vout, the target and the compression performed.

$$V_{out} = \frac{Prestres}{Target} \times 5 \text{ VDC}$$

Relay Target (positions 5 and 6): Output where the contact of a NA relay is closed when the target charge ("Compress target") is reached. This contact remains closed while the charge - percentage bar graph is fully filled.

Relay error (positions 7 and 8): Output where the contact of a NA relay is closed when the device detects a measuring error (overload). This contact remains closed while the equipment performs the tare and restarts.

Start (positions 9 and 10): Signal input command to act in the same way as the START [6] command to remotely execute the tare function of the equipment to start a new measurement.

The table below contains the description of the pin sequence used in the PLC interface connector, and the specifications of each of these channels.

Table with pin specifications and communication channels of the PLC Interface

N°	Description	Type	Voltage		Current		Isolation
			Min	Max	Min	Max	
1	GND	-	0	0	-	-	0 VDC
2	Not connected	-	-	-	-	-	0 VDC
3	GND	Output	0	0	-	-	0 VDC
4	Vout +		0.0 V	10.0 V	1mA	10 mA	0 VDC
5	Relay Target	Output	-24 V	24 V	-	1A	500 VDC
6	Relay Target		-24 V	24 V	-	1A	500 VDC
7	Relay error	Output	-24 V	24 V	-	1A	500 VDC
8	Relay error		-24 V	24 V	-	1A	500 VDC
9	Start -	Input	0	0	10mA	60mA	500 VDC
10	Start +		1.5 V	24 V	10mA	60mA	500 VDC

The connection cable to be used with the PLC Interface connector must be manufactured by the user according to the configuration of the equipment PiezoClamping will be connected to, using the connector provided as an accessory together with the product packaging at the end of this cable.

10. Technical support, warranty terms and statement of responsibility

If the equipment is defective or malfunctioning, check if the problem is related to any of those listed in topic 8.1 and follow the troubleshooting instructions. If the problem remains or is not listed in topic 8.1, contact the ATCP Physical Engineering for further analysis and possible repairs.

ATCP Physical Engineering offers two-year warranty from the date of purchase. The warranty covers material and/or manufacturing defects. After the end of the warranty period, services, parts and other expenses will be charged. Factors that may invalidate the warranty agreement:

- Lack of care as recommended by this manual in what regards the installation and operation of the equipment.
- Accident, fall, inadequate installation or any other damage caused by incorrect use or action of natural agents.
- Violation, repair or any other modification or alteration performed in the equipment or in its parts by ATCP Physical Engineering non-authorized personnel.

ATCP Physical Engineering takes full technical and legal responsibility for the PiezoClamping prestress and charge meter for piezoelectric ceramics and guarantees that all the information contained in this Installation and Operation Manual is true.

- ▲ Reading all the information contained in this installation and operation manual is indispensable for the correct use of the equipment.
- ▲ Do not use the equipment for any other purposes other than the ones that have been indicated by this manual.

(This page intentionally left blank)

11. References

- [1] LANGEVIN, P.; Procédé et appareils d'émission et de réception des ondes élastiques sous-marines à l'aide des propriétés piézo-électriques du quartz Procédé et appareils d'émission et de réception des ondes élastiques sous-marines à l'aide des propriétés piézo-électriques du quartz, French Patent 505.703,1920.
- [2] FREDERICK, J.; Ultrasonic Engineering: John Wiley & Sons, Inc. - 1965.
- [3] PROKIC, M.; Piezoelectric Converters Modeling and Characterization, 2° edição, MPI Interconsulting, august 2004.
- [4] PIEZOELECTRIC CERAMICS Properties & Applications. Morgan Advanced Materials.
- [5] BUNAI, C.; The Torque-Tension Relationship Gets Stretched, American Fastener Journal, May/June 2012 Issue - Vol. 28 No. 3.